



GENUINE PARTS

INSTALLATION INSTRUCTIONS

1 Description : Crossbar Kit

2 Application : Rogue

Forward driving direction

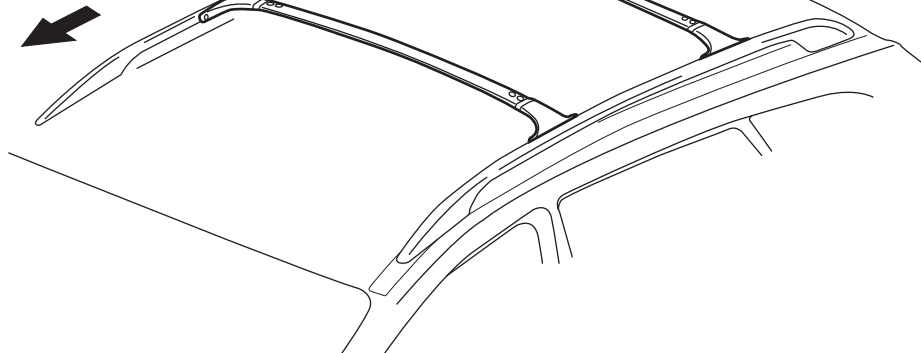

3 Part Number : G3805-JM00A

4 Kit Contents

No.	QTY	Part Name
①	1	Front crossbar assembly
②	1	Rear crossbar assembly
③	1	T-30 Torx wrench
④	8	T-30 Torx bolt
⑤	1	Installation instructions

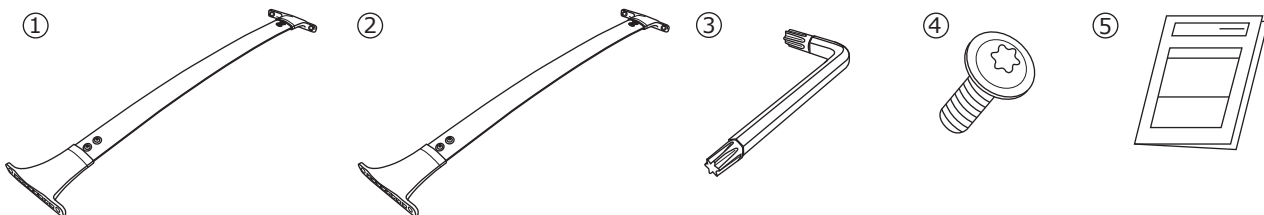

5 Tools Required

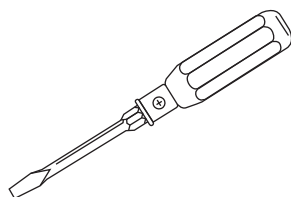

Flathead screwdriver

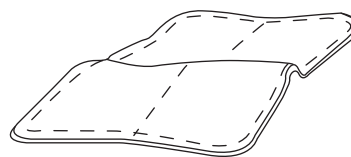

Rag (soft cloth)

INSTALLATION INSTRUCTIONS - CROSSBAR KIT

6 PRE-INSTALLATION CAUTIONS/NOTES:

CAUTION

- The crossbar is not designed to directly bear loads.

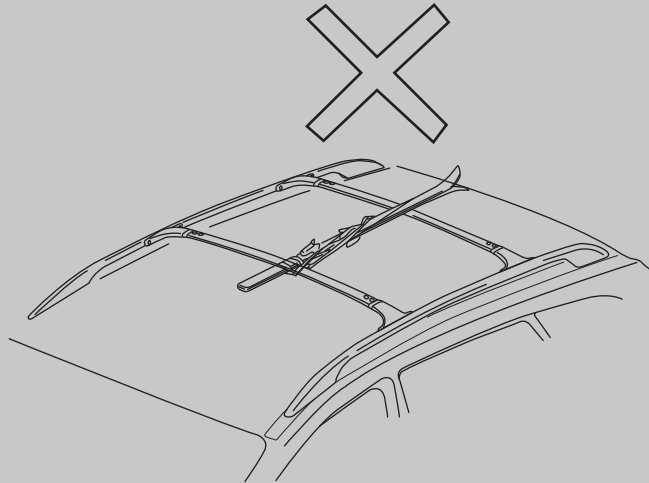

CAUTION

- Always evenly distribute the luggage and appropriate crossbar attachment on the crossbar. Do not load more than 100 lbs.(45kg). Be careful that your vehicle does not exceed the Gross Vehicle Weight Rating (GVWR) or its Gross Axle Weight Rating (GAWR Front and Rear). The GVWR and GAWR are located on the Safety Compliance Certification Label (located on the driver's door pillar). For more information regarding GVWR and GAWR, refer to "Technical and Customer Information" .

Ensure both front and rear crossbars are installed correctly. See Installation Instructions for details.

- Use care when placing or removing items on the crossbar.
If you cannot comfortably lift the items onto the crossbar from the ground, use a ladder or stool.

Precautions and points to check before driving

- Initially, there may be some loosening of the screws. Retighten the screws as necessary (after driving approximately 60miles(100km)).
- Verify that the vehicle height with the crossbar attached is within limits before entering tunnels or areas of restricted height such as parking garages.

INSTALLATION INSTRUCTIONS - CROSSBAR KIT

7 INSTALLATION PROCEDURE:

⚠ CAUTION

- During installation, take precautions to prevent scratching or damaging the vehicle.
- Perform installation in a spacious area to allow opening and closing the vehicle doors.

1. Cleaning the Installation Area on the Vehicle

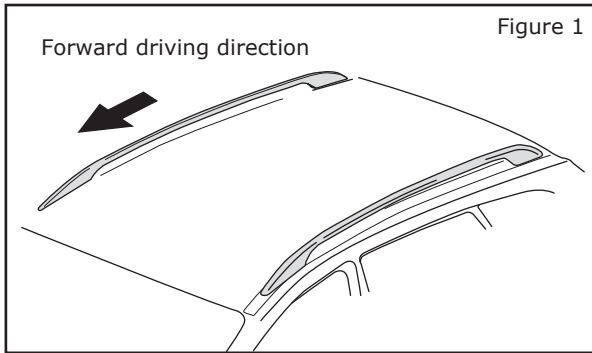

- (1) Use a damp cloth to clean the area where the crossbar will be installed (as indicated by the shaded areas) as shown in Figure 1.

2. Preparing for Installation

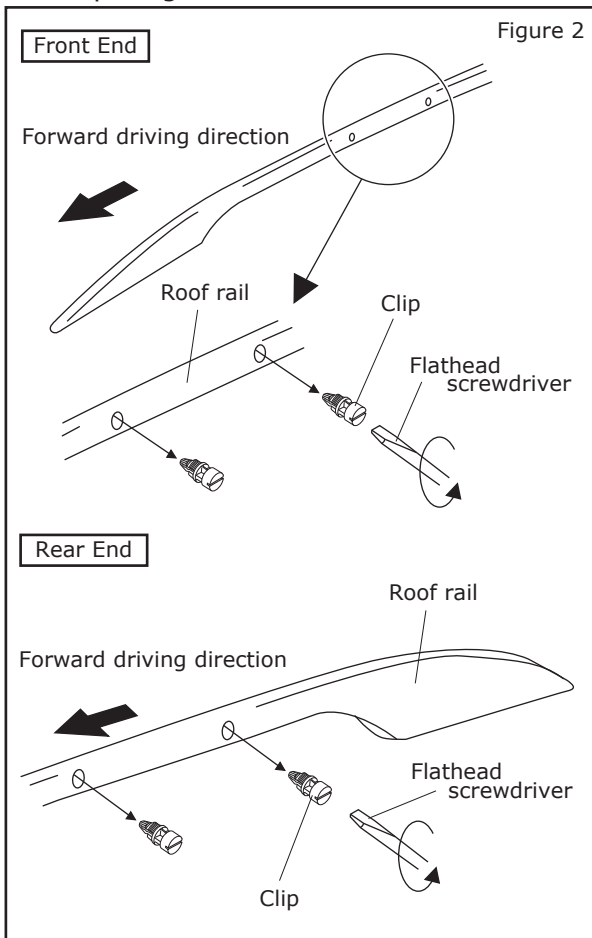

- (1) Use a flathead screwdriver to loosen and remove the clips attached to the left roof rail at two positions on the front and two positions on the rear.
- (2) Repeat step 1 on the right side roof rail.

⚠ CAUTION

Roof rail clips are not reusable and should be discarded after removing.

INSTALLATION INSTRUCTIONS - CROSSBAR KIT

3. Preparation for Front crossbar assembly^①

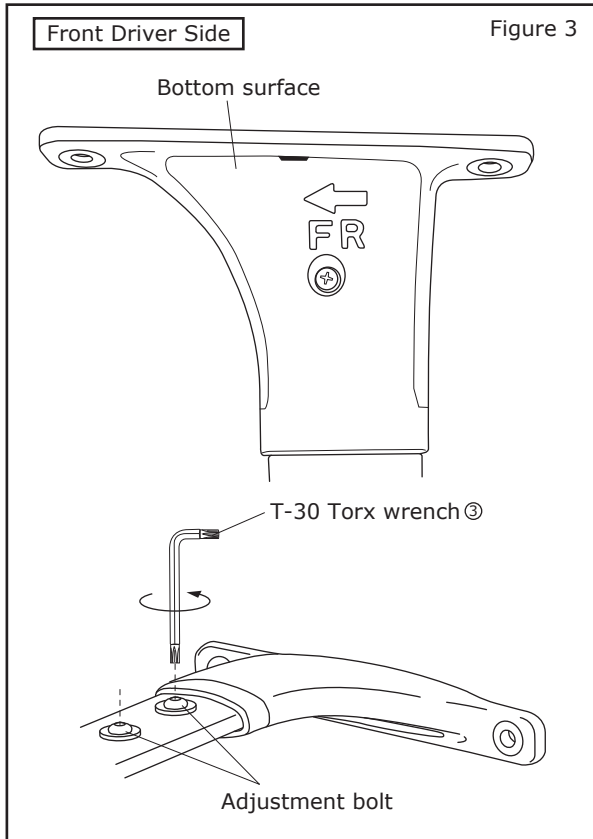

- (1) Identify and obtain the Front crossbar by using Figure 3.
Note: Crossbar "FR" stamping should always point toward front of Car.
- (2) Loosen the adjustment bolts on both sides of the Front crossbar assembly^① using the T-30 torx wrench^③.

4. Installation of Front crossbar assembly^①

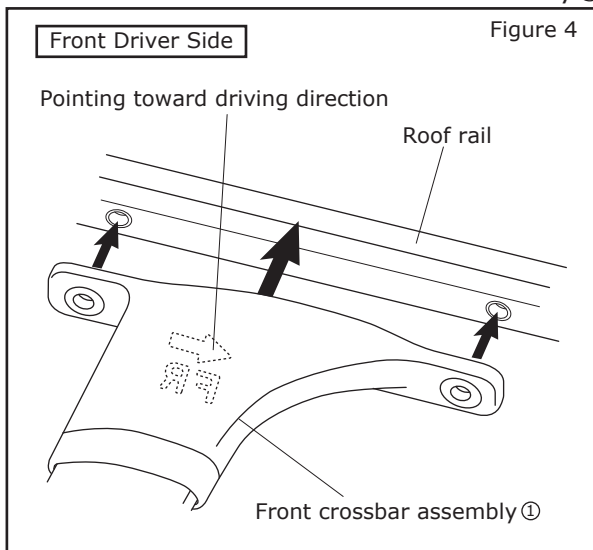

- (1) Align Front crossbar assembly to the driver roof rail mounting location as shown in Figure 4.

INSTALLATION INSTRUCTIONS - CROSSBAR KIT

4. Installation of Front crossbar assembly① cont'd

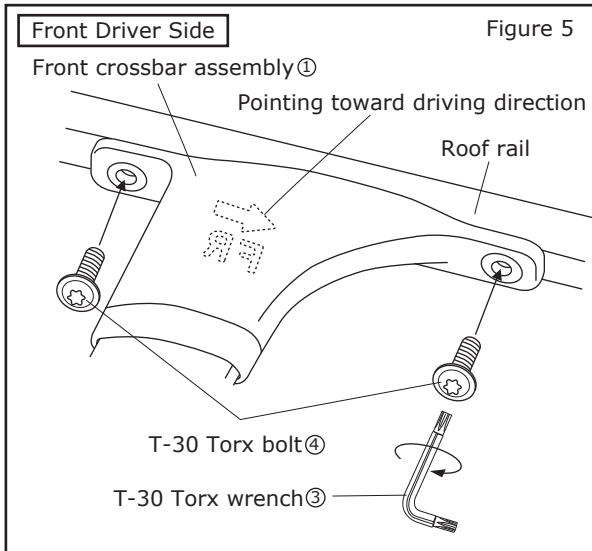

- (2) While aligned, install and fasten T-30 torx bolts ④ and Front crossbar assembly ① to the roof rail mounting location as shown in Figure 5.

Note: Torque to 4.2 - 6.3 ft-lbs. (5.6-8.4 N-m).

- (3) Repeat steps (1) & (2) on the right side roof rail.

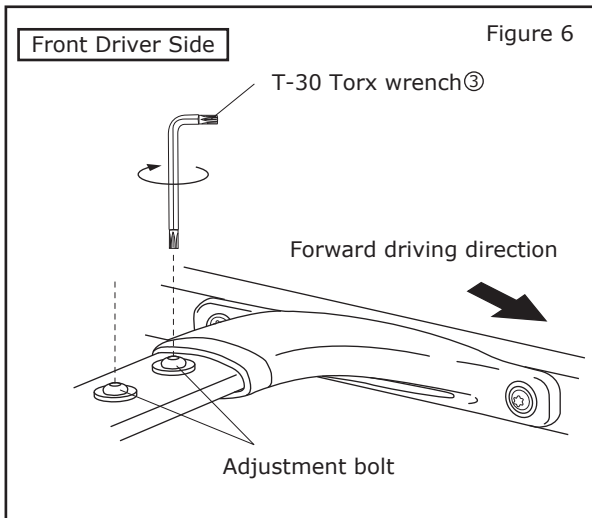

- (4) Fasten adjustment bolts on the left side of the Front crossbar assembly ① using the T-30 torx wrench ③.

Note: Torque to 4.2 - 6.3 ft-lbs. (5.6-8.4 N-m).

INSTALLATION INSTRUCTIONS - CROSSBAR KIT

5. Preparation for Rear crossbar assembly^②

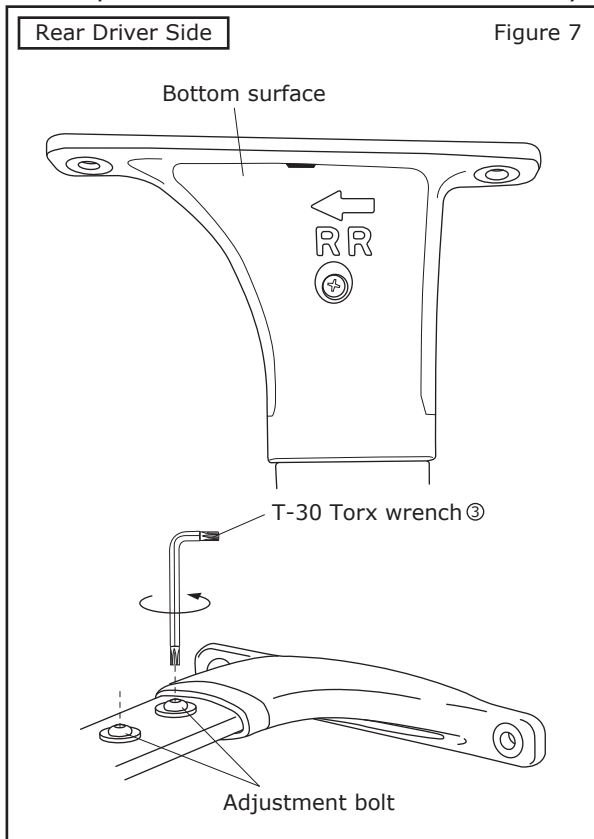

(1) Identify and obtain the Rear crossbar by using Figure 7.

Note: Crossbar "RR" stamping should always point toward front of Car.

(2) Loosen the adjustment bolts in both sides of the Rear crossbar assembly^② using the T-30 torx wrench^③.

6. Installation of Rear crossbar assembly^②

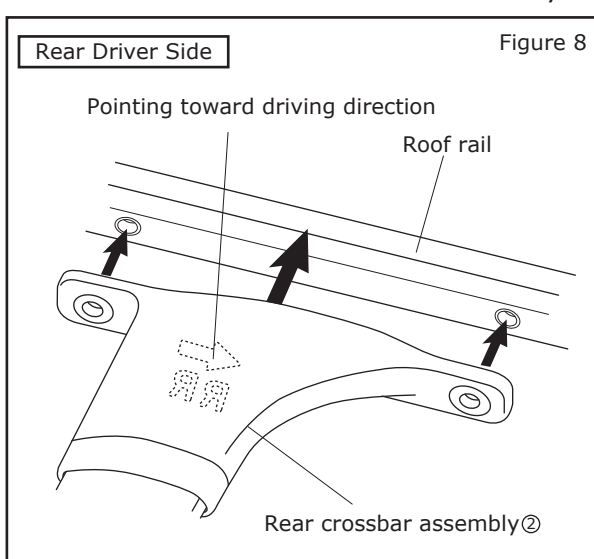

(1) Align Rear crossbar assembly to the driver roof rail mounting location as shown in Figure 8.

INSTALLATION INSTRUCTIONS - CROSSBAR KIT

6. Installation of Rear crossbar assembly^② cont'd

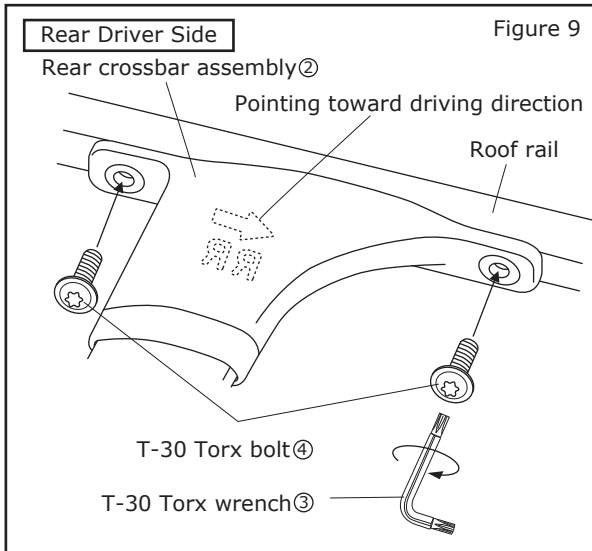

- (2) While aligned, install and fasten T-30 torx bolts^④ and Rear crossbar assembly^② to the roof rail mounting location as shown in Figure 9.

Note: Torque to 4.2 - 6.3 ft-lbs. (5.6-8.4 N-m).

- (3) Repeat steps (1) & (2) on the right side roof rail.

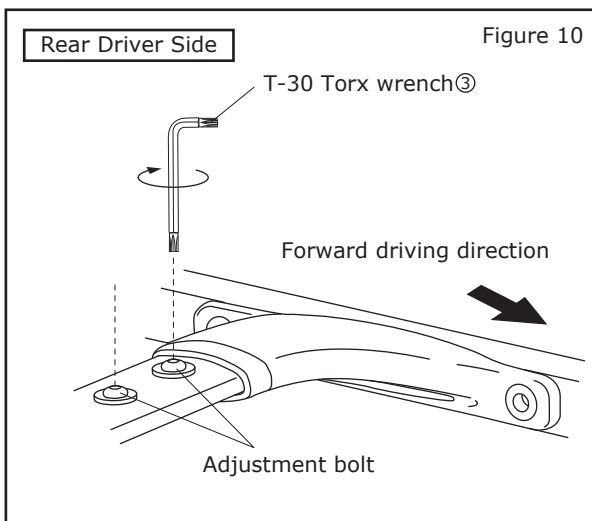

- (4) Fasten adjustment bolts on the left side of the Rear crossbar assembly^② using the T-30 torx wrench^③.

Note: Torque to 4.2 - 6.3 ft-lbs. (5.6-8.4 N-m).

7. Points to Check after Installation

- (1) Check the tightness of the crossbar screws after installation.
- (2) Gently wiggle the crossbar to check for problems. Verify that there are no noises or movement when pushed and pulled.
- (3) If you notice problems in steps 1-2, follow the installation instructions again.